

6% - 8% AIR ENTRAINED  
 35 MPa (5000 psi) @ 28 DAYS  
 AS PER CSA A23.4-09 STANDARD

ALL DIMENSIONS DEFAULT TO  
 MILLIMETERS  $\frac{\text{mm}}{\text{[in]}}$

REINFORCEMENT IN WELL TILES IS A  
 LAYERS OF 6" C/C 2-WAY WIRE MESH

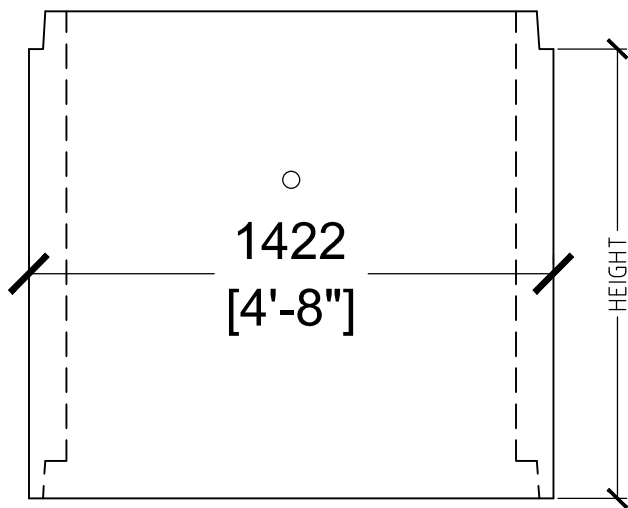
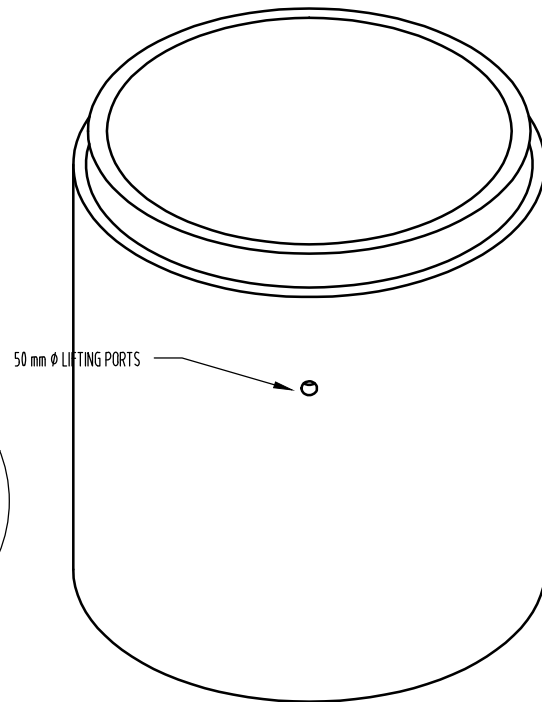
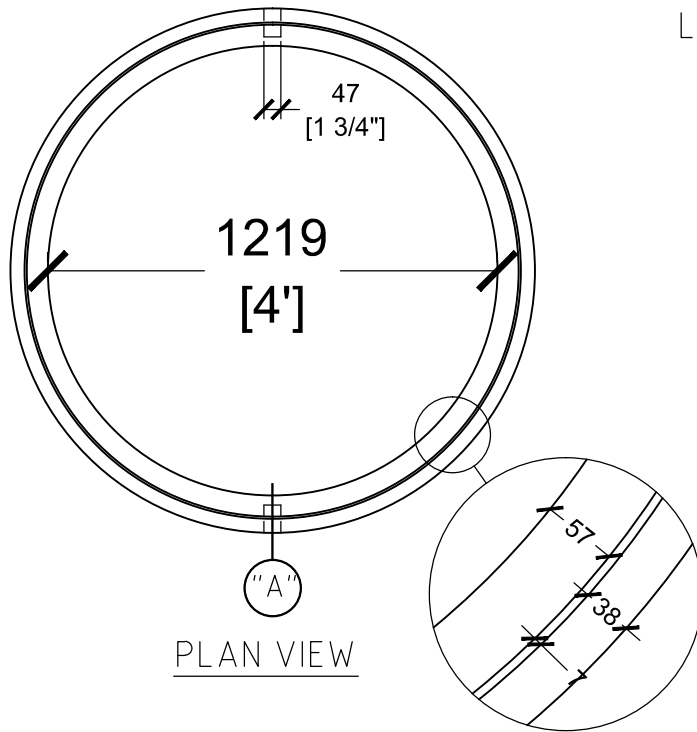

4' WELL TILES AVAILABLE IN FIVE  
 DIFFERENT HEIGHTS, SEE LIST BELOW :

- 12 " : WEIGHT 308.44 KG / 680.00 LBS
- 18 " : WEIGHT 462.66 KG / 1020.00 LBS
- 36 " : WEIGHT 925.32 KG / 2040.00 LBS
- 48 " : WEIGHT 1233.76 KG / 2720.00 LBS
- 72 " : WEIGHT 1850.64 KG / 4080.00 LBS

MOOSE CREEK CEMENT PRODUCTS (2006) LIMITED  
 4'  $\phi$  WELL TILES

NOT TO SCALE

DATE JUNE 2011

16525 SIXTH RD, MOOSE CREEK, ON  
 K0C 1W0

PHONE : (613)-538-2381  
 FAX : (613)-538-4870

