

PLAN VIEW

SPECIFICATIONS:

NOMINAL TANK SIZE
3600 LITER SEPTIC TANK

TOTAL CAPACITY
4355 LITERS (958 GAL)
3630 LITERS (798 GAL) TO OUTLET

ALL DIMENSIONS DEFAULT TO
MILLIMETERS [in]

GENERAL NOTES:

- 1) CONCRETE TO BE 30 MPa @ 28 DAYS WITH 5-8% AIR ENTRAINMENT
- 2) CONCRETE MIX IS NON-SULPHATE RESISTANT
- 3) REINFORCEMENT TO CONFORM TO G30.15 AND CAN/CSA G30.18
- 4) REINFORCEMENT: TOP SLAB REINFORCEMENT
-10M REBAR EQUALLY SPACED IN BOTH DIRECTION
BOTTOM SLAB REINFORCEMENT
-10M REBAR EQUALLY SPACED IN BOTH DIRECTION
WALL REINFORCEMENT
-FIBERGLASS MESH ADDED IN CONCRETE MIX
- 5) MINIMUM CONCRETE COVER OVER REINFORCEMENT IS 25.4mm / 1"
- 6) CERTIFIED MINIMUM BURIAL DEPTH: 0.6M (24")
- 7) WEIGHT OF TOP SLAB = 780 KG / 1720 LBS
- 8) WEIGHT OF TANK SECTION = 2805 KG / 6185 LBS
- 9) ASSEMBLED WEIGHT = 3585 KG / 7905 LBS
- 10) CHAMBER DIVIDER IS CAST SEPARATELY
- 11) NO CENTER JOINT IN TANKS
- 12) 100mmØ INLET AND 75mmØ OUTLET PVC PIPE STUB
- 13) TOP OF OUTLET FITTING EXTENDS TO AT LEAST THE HEIGHT OF CHAMBER DIVIDER WITH 25mm MINIMUM AIR SPACE
- 14) PRODUCT IS FACTORY ASSEMBLED AND AS PER CSA A23.4-09 STANDARD AND CSA B 66-00 STANDARD

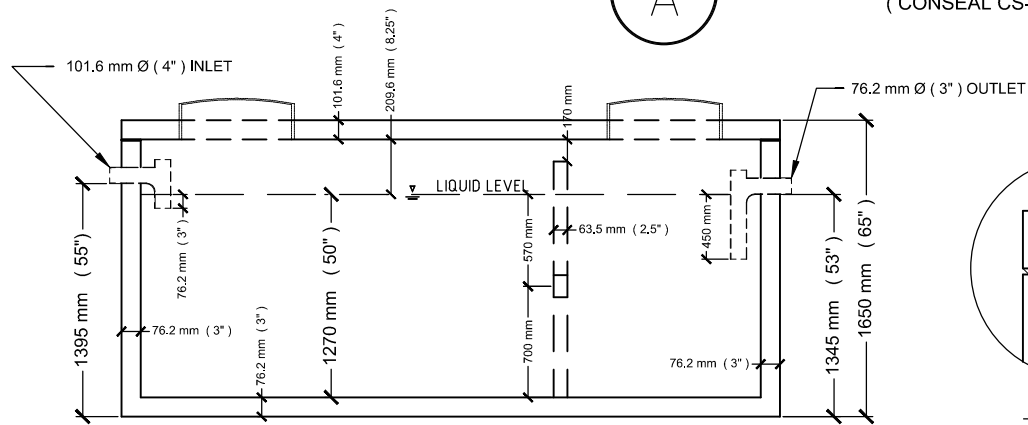

CROSS SECTION A

JOINT SEALANT
(CONSEAL CS-102)

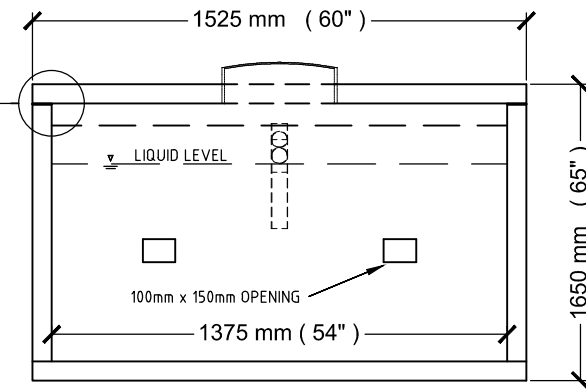
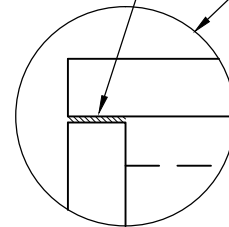

CROSS SECTION B

16525 SIXTH RD, MOOSE CREEK, ON
KOC 1W0
PHONE : (613)-538-2381
FAX : (613)-538-4870

MOOSE CREEK CEMENT PRODUCTS (2006) LIMITED
CONCRETE 798 GALLON / 3630 LITER SEPTIC TANK

SCALE

NOT TO SCALE

DATE

JULY 2011

